

Millipak PMAC Controller Wiring

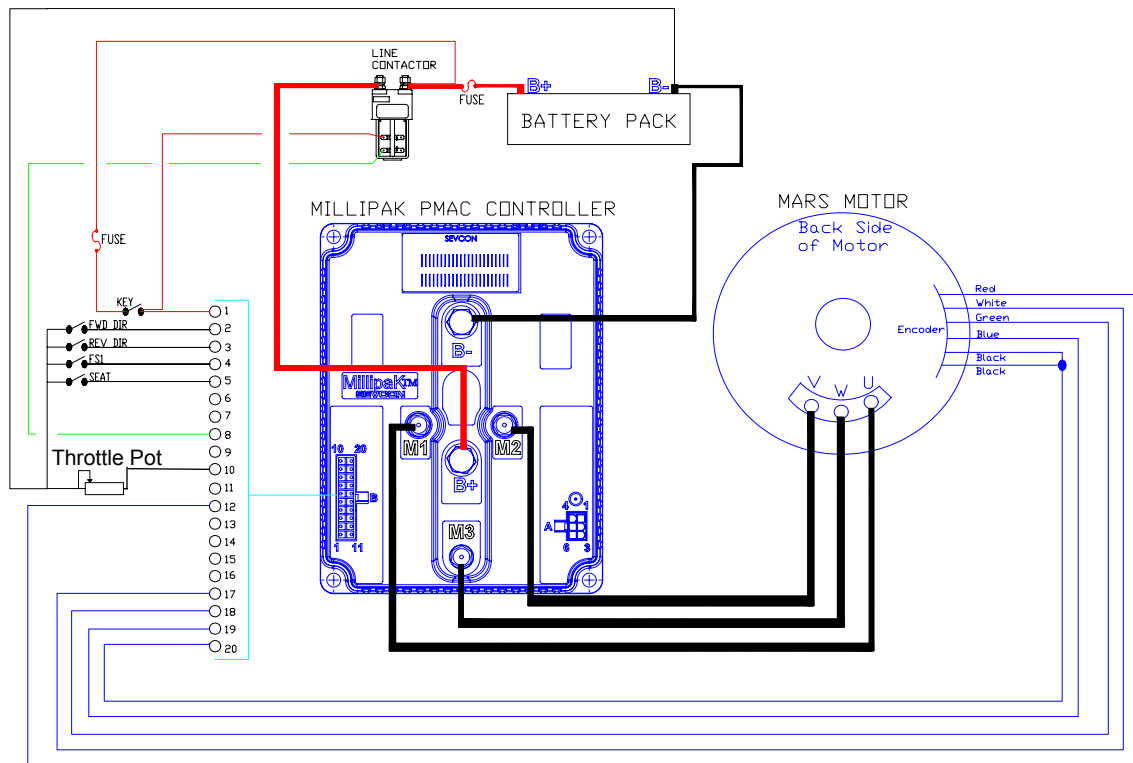

- Line contactor is required. 24 Volt default setting.
- Fuses are recommended in case of wiring short circuit.
- ~~If not using a Seat Switch, replace switch with jumper wire.~~
- Accelerator Potentiometer should travel from 0 to 5k for Min. to Max. Speed.
- Controller should be mounted to a paint free metal surface on vehicle and surface should be coated with thermal transfer grease.
- When first testing vehicle make sure drive wheels are off the ground and free to rotate.